



TL-Series Servo Motors

Catalog Numbers TLY-A110, TLY-A120, TLY-A130, TLY-A220, TLY-A230,
TLY-A2530, TLY-A2540, TLY-A310

Topic	Page
Catalog Number Explanation	3
Before You Begin	4
Installation and Maintenance Guidelines	4
Install the TL-Series Motor	8
Requirements for Motor Mounting	8
Power Cable Shielding	9
Installing the Motor	10
Dimensions	12
Motor Load Force Ratings	17
Connector Data	19
Remove and Install a Shaft Key	21
Specifications	22
Accessories	23
Additional Resources	24

About This Publication

This publication provides installation instructions for the TL-Series motors categorized with a TLY catalog number.

Use this document if you are responsible for installing these Allen-Bradley motor products. Please read all instructions before installing this motor.

Important User Information

Solid state equipment has operational characteristics differing from those of electromechanical equipment. Safety Guidelines for the Application, Installation and Maintenance of Solid State Controls, publication SGI-1.1, available from your local Rockwell Automation sales office or online at <http://literature.rockwellautomation.com>. It describes some important differences between solid state equipment and hard-wired electromechanical devices. Because of this difference, and also because of the wide variety of uses for solid state equipment, all persons responsible for applying this equipment must satisfy themselves that each intended application of this equipment is acceptable.





In no event will Rockwell Automation, Inc. be responsible or liable for indirect or consequential damages resulting from the use or application of this equipment.

The examples and diagrams in this manual are included solely for illustrative purposes. Because of the many variables and requirements associated with any particular installation, Rockwell Automation, Inc. cannot assume responsibility or liability for actual use based on the examples and diagrams.

No patent liability is assumed by Rockwell Automation, Inc. with respect to use of information, circuits, equipment, or software described in this manual.

Reproduction of the contents of this manual, in whole or in part, without written permission of Rockwell Automation, Inc., is prohibited.

Throughout this manual, when necessary, we use notes to make you aware of safety considerations.

<p>WARNING</p> 	<p>Identifies information about practices or circumstances that can cause an explosion in a hazardous environment, which may lead to personal injury or death, property damage, or economic loss.</p>
<p>IMPORTANT</p>	<p>Identifies information that is critical for successful application and understanding of the product.</p>
<p>ATTENTION</p> 	<p>Identifies information about practices or circumstances that can lead to personal injury or death, property damage, or economic loss. Attentions help you identify a hazard, avoid a hazard and recognize the consequences.</p>
<p>SHOCK HAZARD</p> 	<p>Labels may be on or inside the equipment, for example, a drive or motor, to alert people that dangerous voltage may be present.</p>
<p>BURN HAZARD</p> 	<p>Labels may be on or inside the equipment, for example, a drive or motor, to alert people that surfaces may reach dangerous temperatures.</p>

Catalog Number Explanation

TL Y - A 3 10 M - B J 6 2 AA

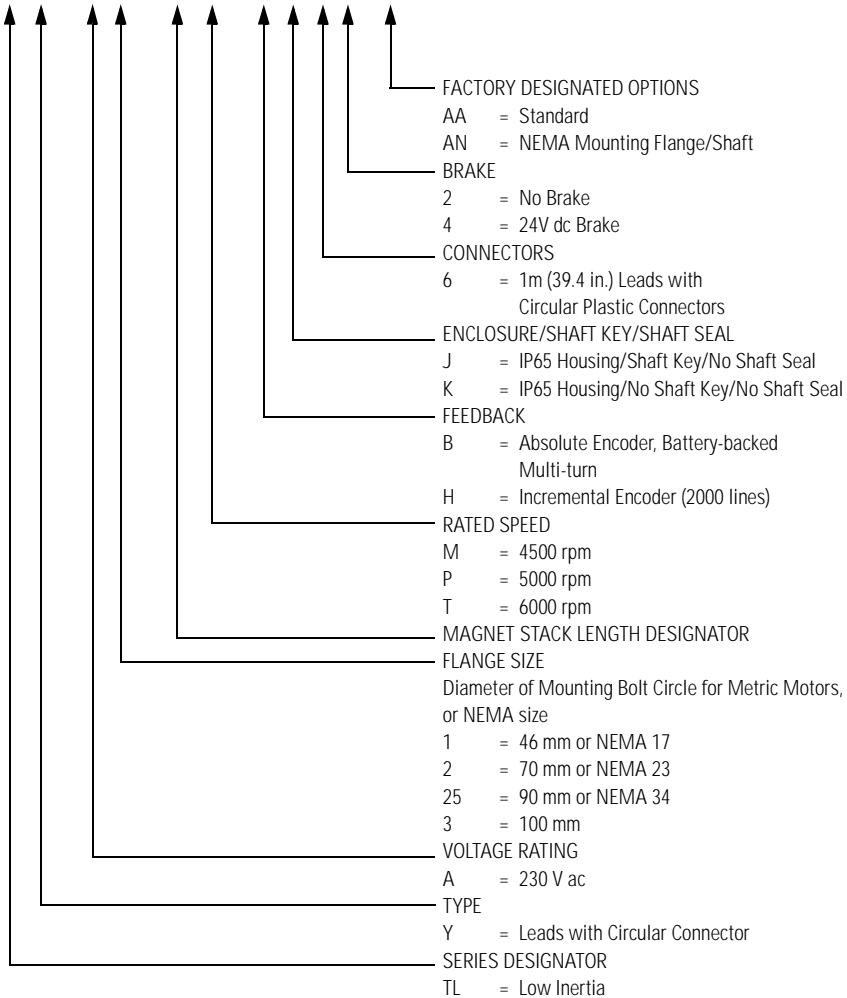

Before You Begin

Before unpacking the product, inspect the shipping carton for damage. If damage is visible, immediately contact the shipper and request assistance. Otherwise, proceed with unpacking.

Remove the motor carefully from its shipping container, and visually inspect the motor for any damage. Carefully examine the motor frame, front output shaft, and mounting pilot for any defects.

Keep the original packing material in case you need to return the product for repair or transport it to another location. Use both the inner and outer packing cartons to verify adequate protection for a unit returned for service.

ATTENTION



Do not attempt to open and modify the motor. Modifications that can be performed in the field are described in this manual, other changes should not be attempted.

Only a qualified Allen-Bradley employee can service this type of motor.

Failure to observe these safety procedures could result in personal injury or damage to equipment.

Installation and Maintenance Guidelines

This section advises you on how to install your product so it provides safe and reliable service.

To Prolong Motor Life

Thoughtful design and proper maintenance can increase the life of a servo motor.

- Always install the motor with the cable entry point(s) positioned underneath the motor housing, and provide a drip loop in each cable. A drip loop is a downward bend in the cable that lets water gather and drip off the cable rather than continue to flow along the cable. These two installation practices greatly reduce the potential for moisture related problems.

Recommended Connector Orientation with Drip Loop



Motor is positioned so cable enters from above, and cable lacks drip loop.

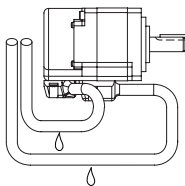

Cable enters beneath the motor, and drip loop is formed.

- Avoid installing the motor with the shaft pointing upward. This orientation increases the risk of contaminant ingress.
- Avoid spraying liquids under pressure directly on the junction of the motor shaft, housing, and connectors, as well as the enclosure joints. Fluids under pressure can be forced around worn seals, and contaminate the motor bearings. Bearing contamination will significantly shorten the life of a servo motor.

-
- If design requirements permit, provide shields that protect the motor housing, shaft, seals and their junctions from product contamination, caustic agents, and high pressure fluids.
 - Replace the optional shaft seal at or before its expected twelve-month lifetime elapses. Refer to Remove and Install a Shaft Key on page 21 for more information on shaft seals.
 - Inspect the motor and seals for damage or wear on a regular basis. If damage or adverse wear is suspected, replace the item.
 - If desired, the motor front flange may be sealed to the driven equipment by a bead of RTV around the periphery of the motor to equipment joint. Use of a gasket or RTV on the mating surfaces may cause misalignment of the shaft and result in damage to the motor and driven equipment.
 - Brakes on these servo motors are holding brakes. The brakes are spring-set, and release when voltage is applied to the brake coil. A power source, either external or internal to the servo drive, is required to disengage the brake. The power source may be applied by the machine controller.

If system main power fails, holding brakes can withstand occasional use as stopping brakes. However, this is potentially damaging to the system, increases brake wear, and reduces brake life.

IMPORTANT

Holding brakes are not designed to stop rotation of the motor shaft, nor are they intended to be used as a safety device. They are designed to hold a motor shaft at 0 rpm for up to the rated brake holding torque.

Follow these steps to prevent shaft rotation.

1. Command the servo drive to 0 rpm.
2. Verify the motor is at 0 rpm.
3. Engage the brake.
4. Disable the drive.

Disabling the drive removes the potential for brake wear caused by a badly tuned servo system oscillating the shaft.

Mechanical Connections

Mechanical connections to the motor shaft, such as couplings and pulleys, require a torsionally rigid coupling or a reinforced timing belt. The high dynamic performance of servo motors can cause couplings, pulleys, or belts to loosen or slip over time. A loose or slipping connection will cause system instability and may damage the motor shaft. All connections between the machine and the motor shaft must be rigid to achieve acceptable system response. Periodically inspect connections to verify their rigidity.

When mounting couplings or pulleys to the shaft, verify that the connections are properly aligned and that axial and radial loads are within the specifications of the motor.

Refer to Motor Load Force Ratings on page 17 for guidelines on how to achieve 20,000 hours of motor bearing life.

ATTENTION



Do not strike the shaft, key, couplings, or pulleys with tools during installation or removal.

Damage may occur to the motor bearings and the feedback device if sharp impact to the shaft is applied during installation of couplings and pulleys, or a shaft key. Damage to the feedback device also may result by applying leverage from the faceplate to remove devices mounted on the motor shaft.

Apply a constant pressure, with a wheel puller for example, to the user end of the shaft to remove a friction fit or a stuck device.

Failure to observe these safety procedures could result in damage to the motor and its components.

A shaft key provides a rigid mechanical connection with the potential for self-alignment, but the key must be properly installed in the keyway. Refer to these sections for additional information:

- Dimensions on page 12 for dimensional information about the key and shaft keyway.
- Remove and Install a Shaft Key on page 21 for recommendations on how to remove and install a shaft key.

Interconnect Cables

Knowledgeable cable routing improves system electromagnetic compatibility (EMC). Refer to Shielding of Brake Wires Within the Power Cable on page 9 for cable shield grounding at the servo drive.

Follow these steps to install the cables.

1. Keep wire lengths as short as physically possible.
2. Route signal cables away from motor and power wiring. Typical signal cables transmit encoder, serial, or analog data at low voltages.
3. Separate cables by 0.3 m (1 ft) minimum for every 9 m (30 ft) of parallel run.
4. Ground both ends of the cable shield and twist the signal wire pairs to prevent electromagnetic interference (EMI) from other equipment.

ATTENTION



High voltage can be present on the shields of a power cable, if the shields are not grounded.

Verify there is a connection to ground for all shields in the power cable.

Failure to observe these safety procedures could result in personal injury or damage to equipment.

Electrical Noise

ElectroMagnetic Interference (EMI), commonly called noise, adversely impacts motor performance by inducing stray signals. Effective techniques to counter EMI include filtering the ac power, shielding and separating signal carrying lines, and practicing good grounding techniques. Effective ac power filtering can be achieved by using isolated ac power transformers or properly installed ac line filters.

To reduce EMI follow these guidelines:

- Physically separate signal lines from motor cabling and power wiring. Do not route signal wires with motor and power wires, and do not route signal wires over the vent openings of servo drives or other electrical power sources.
- Ground all equipment by using a single-point parallel ground system that employs ground bus bars or large straps. If necessary, use additional electrical noise reduction techniques to reduce EMI in noisy environments.

Shaft Seals

You may install the optional shaft seal to protect the front bearing from fluids or fine dust that could contaminate the motor bearing and reduce its lifetime. The IP rating for the motor depends on the usage of shaft seals.

Refer to these sections for additional information:

- Shaft Seal Kits on page 23 lists catalog numbers of seal kits available for your motor.
- Specifications on page 22 briefly describes IP ratings.

Install the TL-Series Motor

Before installing the motor, review and become familiar with the following instructions:

- Requirements for Motor Mounting
- Power Cable Shielding
- Installing the Motor
- Dimensions
- Motor Load Force Ratings
- Connector Data

Requirements for Motor Mounting

All TL-Series motors include a mounting pilot for aligning the motor on a machine. Preferred fasteners are stainless steel. The installation must comply with all local regulations and use of equipment and installation practices that promote electromagnetic compatibility and safety.

ATTENTION

Unmounted motors, disconnected mechanical couplings, loose shaft keys, and disconnected cables are dangerous if power is applied.

Disassembled equipment should be appropriately identified (tagged-out) and have access to electrical power restricted (locked-out).

Before applying power to the motor, remove the shaft key and other mechanical couplings that could be thrown from the shaft.

Failure to observe these safety procedures could result in personal injury.

Power Cable Shielding

Power cables must be shielded, and the cable shield must connect to a ground.

ATTENTION

High voltage can be present on the shields of a power cable, if the shields are not grounded.



Verify there is a connection to ground for all shields in the power cable.

Failure to observe these safety procedures could result in personal injury or damage to equipment.

Verify the separate brake wire shield connects to the overall chassis ground by looping back this brake wire pair as shown in the figure Shielding of Brake Wires Within the Power Cable.

Shielding of Brake Wires Within the Power Cable

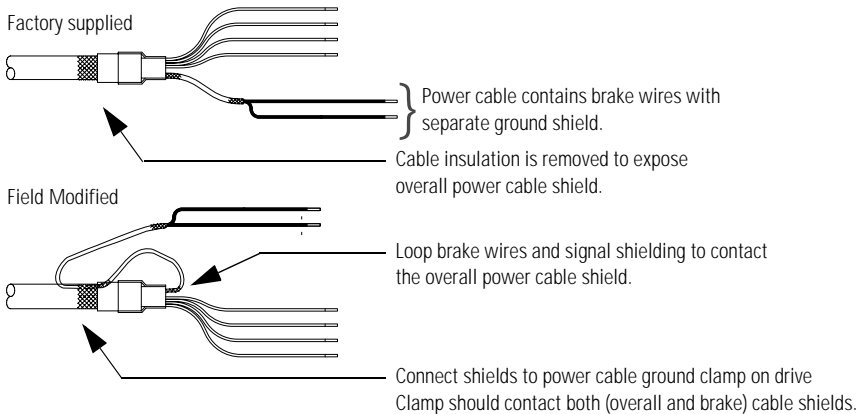

Installing the Motor

Follow these procedures and recommendations to install a TL-Series motor.

ATTENTION



Servo motors are not for direct connection to an ac power line.

Servo motors are designed for connection to a servo drive that controls the application of ac power.

Failure to observe these safety procedures could result in damage to the motor and equipment.

ATTENTION



Do not strike the shaft, couplings, or pulleys with tools during installation or removal.

Damage may occur to the motor bearings and the feedback device if sharp impact to the shaft is applied during installation of couplings and pulleys.

Failure to observe these safety procedures could result in damage to the motor and its components.

1. Allow sufficient clearances in the area of the motor for it to stay within its specified operating temperature range.
 - Obtain the specified motor thermal rating by mounting the motor on a surface with heat dissipation equivalent to an aluminum heatsink of the following dimensions.

Motor Frame Size	Heatsink Dimensions (H x W x D) Approx. ⁽¹⁾	
	millimeters	(inches)
TLY-A1xx	203.0 x 203.0 x 6.4	(8 x 8 x 0.25)
TLY-A2xx	254.0 x 254.0 x 6.4	(10 x 10 x 0.25)
TLY-A25xx, TLY-3xx	305.0 x 305.0 x 12.7	(12 x 12 x 0.5)

⁽¹⁾ Ambient temperature of the specified heatsink is 40 °C (104 °F).

- Refer to Specifications on page 22 for the operating range.
- Do not install the motor in an area with restricted airflow, and keep other heat producing devices away from the motor.

ATTENTION

Outer surfaces of the motor can reach high temperatures, 110 °C (230 °F) during motor operation.

Take precautions to prevent accidental contact with hot surfaces. Locate the motor and route cable connections to avoid contact with hot surfaces.

Failure to observe these safety procedures could result in personal injury or damage to equipment.

2. Position the motor with the cable connections beneath the motor.

Refer to Recommended Connector Orientation with Drip Loop on page 4 for a visual reference of correct motor and cable positioning.

3. Properly mount and align the motor.

- Refer to Dimensions on page 12 to properly locate and size motor mounts.
- Do not exceed the Motor Load Force Ratings on page 17. The tables list the radial and axial shaft load limitations of your motor.

4. Connect the feedback, and the combined power and brake cables after the motor is mounted.**ATTENTION**

Mount the motor so exposure to dust and liquids is minimized for both the motor and its cable connections, and restrain cables to prevent uneven tension or flexing at the connectors.

Short circuits in the feedback, power, or brake circuits may result from exposure of the unsealed motor cable connectors to dust or liquids, or by uneven forces at the connector housing.

Failure to observe these safety procedures could result in personal injury or damage to the motor and equipment.

ATTENTION

Servo drive power must be turned off before connecting or disconnecting the cables to the motor, and if a cable is left disconnected at the motor end.

Arcing or unexpected motion could occur if the feedback, power or brake cables are connected or disconnected while power is applied to the servo drive.

Failure to observe these safety procedures could result in personal injury or damage to the motor and equipment.

Dimensions

Dimensions are supplied for non-brake motors. Footnotes provide additional dimensions for brake motors, and tolerances for common dimensions. All dimensions are approximate.

References for Motor Dimensions

Mounting pattern has two holes for A110 through A130 (shown). All others have four holes.

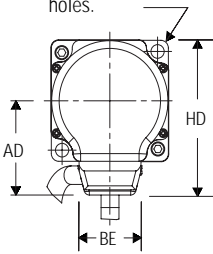

Motor Dimensions for Metric Frame

Mounting pattern has two threaded holes for A120 and A130 (shown). All others have four holes.

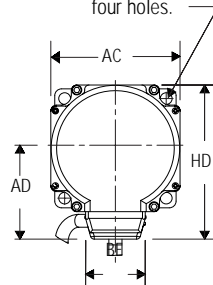

Motor Dimensions for NEMA Mount

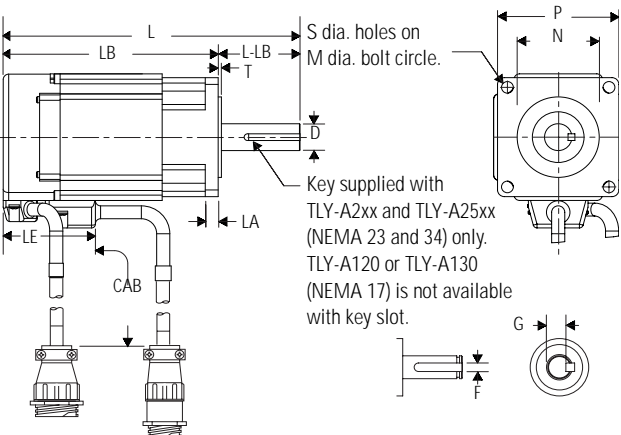
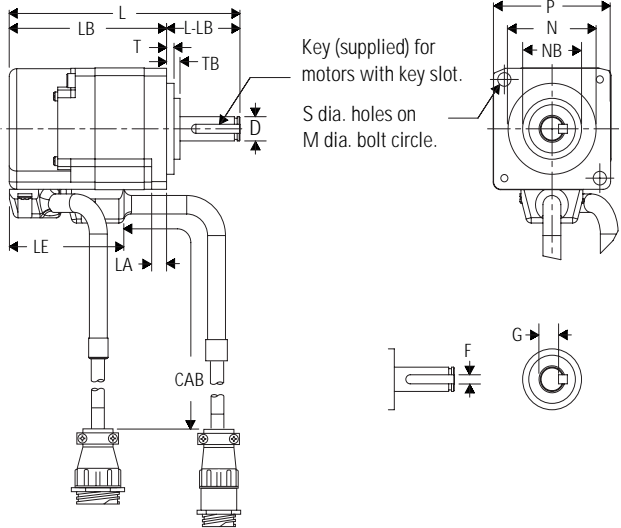

Metric Frame Dimensions, Approx.

Motor Series	AD mm (in.)	BE mm (in.)	D ¹ mm (in.)	HD mm (in.)	L ² mm (in.)	L-LB ³ mm (in.)	LA mm (in.)	LB ² mm (in.)	LE ² mm (in.)	M mm (in.)
110	31.1 (1.22)	21.0 (0.83)	8.0 (0.315)	51.1 (2.01)	78.5 (3.09)	25.0 (0.984)	5.0 (0.20)	53.5 (2.11)	39.1 (1.54)	46.0 (1.811)
120					84.5 (3.33)			59.5 (2.34)		
130					98.5 (3.88)			73.5 (2.89)		
220	43.0 (1.69)		12.0 (0.4724)	73.0 (2.87)	106.1 (4.18)	30.0 (1.181)	6.0 (0.24)	76.1 (3.00)	42.8 (1.69)	70.0 (2.76)
230					128.1 (5.04)			98.1 (3.86)		
2530	53.0 (2.09)	27.6 (1.09)	16.0 (0.6299)	93.0 (3.66)	134.7 (5.30)	35.0 (1.378)	8.0 (0.32)	99.7 (3.93)	43.8 (1.72)	90.0 (3.54)
2540					143.7 (5.66)			108.7 (4.28)		
310	56.0 (2.20)			99.0 (3.90)	179.2 (7.06)			144.2 (5.68)	57.1 (2.25)	100.0 (3.94)

Metric motor frames are designed to metric dimensions. Inch dimensions are a mathematical conversion.

- Tolerance for this dimension is: TLY-A1xx-0.009 mm (-0.0004 in.); TLY-A2xx-0.011 mm (-0.0004 in.); TLY-A25xx-0.011 mm (-0.0004 in.); TLY-A310-0.011 mm (-0.0004 in.).
- TLY-A110, TLY-A120, or TLY-A130 motor with brake, add 35.6 mm (1.40 in.) to L, LB, and LE.
TLY-A220 and TLY-A230 motor with brake, add 34.6 mm (1.36 in.) to L, LB, and LE.
TLY-A2530, or TLY-A2540 motor with brake, add 36.6 mm (1.44 in.) to L, LB, and LE.
TLY-310 motor with brake, add 23.0 mm (0.90 in.) to L, LB, and LE.
- Tolerance for this dimension is: ± 1.0 mm (± 0.039 in.).

Metric Frame Dimensions, Approx. (cont.)

Motor Series	N ⁴ mm (in.)	NB mm (in.)	P mm (in.)	S ⁵ mm (in.)	T mm (in.)	TB mm (in.)	CAB ⁶ mm (in.)	G ⁷ mm (in.)	F ⁸ mm (in.)	Key ⁹ mm (in.)
TLY-A										
110	30.0 (1.1811)	20.0 (0.79)	40.0 (1.57)	4.5 (0.177)	2.5 (0.10)	4.5 (0.18)	1000 (39.4)	6.2 (0.244)	3.0 (0.118)	3 x 3 x 15 (0.118 x 0.118 x 0.59)
120										
130										
220	50.0 (1.9685)	27.0 (1.06)	60.0 (2.36)	5.5 (0.217)	3.0 (0.12)	7.0 (0.28)		9.5 (0.374)	4.0 (0.157)	4 x 4 x 15 (0.158 x 0.158 x 0.59)
230										
2530	70.0 (2.7556)	34.0 (1.34)	80.0 (3.15)	6.6 (0.260)	3.0 (0.12)	7.0 (0.28)		13.0 (0.512)	5.0 (0.197)	5 x 5 x 20 (0.197 x 0.197 x 0.79)
2540			86.0 (3.39)							
310			80.0 (3.15)							

Metric motor frames are designed to metric dimensions. Inch dimensions are a mathematical conversion.

- 4 Tolerance for this dimension is: TLY-A1xx -0.021 mm (-0.0008 in.); TLY-A2xx -0.025 mm (-0.001 in.); TLY-A25xx -0.03 mm (-0.0012 in.); TLY-A310 -0.03 mm (-0.0012 in.).
- 5 TLY-A1xx has two mounting holes, TLY-A2xx...TLY-A310 have four mounting holes. Mounting holes are S diameter on M diameter bolt circle.
- 6 Tolerance for cable length is ± 50.0 mm (± 1.97 in.). Minimum bend radius is 15.00 mm (0.59 in.).
- 7 Tolerance for this dimension is: -0.20 mm (-0.008 in.).
- 8 Tolerance for this dimension is: TLY-A1xx -0.006...-0.031 mm (-0.0002...-0.0012 in.); TLY-A2xx, TLY-A25xx and TLY-A3xx -0.012...-0.042 mm (-0.0005...-0.0017 in.).
- 9 X-Y tolerance for this dimension is: TLY-A1xx -0.025 mm (-0.001 in.); TLY-A2xx, TLY-A25xx and TLY-A3xx -0.03 mm (-0.0012 in.). Length is untoleranced.

NEMA Mount Dimensions, Approx.

Motor Series	AC mm (in.)	AD mm (in.)	BE mm (in.)	D ¹ mm (in.)	HD mm (in.)	L ² mm (in.)	L-LB ³ mm (in.)	LA mm (in.)	LB ² mm (in.)	LE ² mm (in.)	M mm (in.)
TLY-A											
120	—	31.10 (1.22)	21.0 (0.83)	6.35 (0.25)	52.0 (2.05)	91.5 (3.603)	27.0 (1.063)	5.0 (0.20)	64.5 (2.54)	39.1 (1.54)	43.8 (1.725)
130						105.5 (4.153)			78.5 (3.09)		
220	60 (2.36)	43.0 (1.69)	27.6 (1.09)	12.70 (0.50)	73.0 (2.87)	137.9 (5.43)	38.1 (1.50)	6.0 (0.24)	99.8 (3.93)	43.3 (1.70)	66.7 (2.625)
230						159.9 (6.30)			121.8 (4.80)		
2530	—	53.0 (2.09)		15.875 (0.625)	96.0 (3.78)	149.2 (5.872)	44.5 (1.752)	8.0 (0.32)	104.7 (4.12)	43.8 (1.72)	98.4 (3.875)
2540			113.7 (4.48)								

NEMA motor flanges and shafts are designed to inch dimensions. Other frame areas are designed to metric dimensions. Conversions are mathematically calculated.

1 Tolerance for this dimension is: TLY-A1xx -0.009 (-0.0004); TLY-A2xx -0.011 (-0.0004); TLY-A25xx -0.011 (-0.0004).

2 TLY-A120, or TLY-A130 motor with brake, add 35.6 mm (1.40 in.) to L, LB, and LE.

TLY-A220, or TLY-A230 motor with brake, add 34.6 mm (1.36 in.) to L, LB, and LE.

TLY-A2530, or TLY-A2540 motor with brake, add 36.6 mm (1.44 in.) to L, LB, and LE.

3 Tolerance for this dimension is: ± 1.0 mm (± 0.039 in.).

NEMA Mount Dimensions, Approx. (cont.)

Motor Series	N ⁴ mm (in.)	NB mm (in.)	P mm (in.)	S ⁵ mm (in.)	T mm (in.)	TB mm (in.)	CAB ⁶ mm (in.)	G ⁷ mm (in.)	F ⁸ mm (in.)	Key ⁹ mm (in.)
120 130	22.0 (0.8661)	—	42.0 (1.65)	8-32 Thread	2.0 (0.08)	—	1000 (39.4)	—	—	—
220 230	38.1 (1.50)	—	56.4 (2.22)	5.5 (0.217)	1.5 (0.06)	—	1000 (39.4)	10.92 (0.43)	3.175 (0.125)	(0.125 x 0.125 x 0.9375)
2530 2540	73.02 (2.875)	—	86.0 (3.39)	5.5 (0.217)	1.6 (0.06)	—	1000 (39.4)	13.13 (0.517)	4.763 (0.1875)	(0.187 x 0.187 x 1.156)

NEMA motor flanges and shafts are designed to inch dimensions. Other frame areas are designed to metric dimensions. Conversions are mathematically calculated.

- 4 Tolerance for this dimension is: TLY-A1xx -0.021 mm (-0.0008 in.); TLY-A2xx -0.025 mm (-0.001 in.); TLY-A25xx -0.03 mm (-0.0012 in.).
- 5 TLY-A1xx has two threaded holes, TLY-A2xx and TLY-A25xx have four mounting holes. Mounting holes are S diameter on M diameter bolt circle.
- 6 Tolerance for cable length is ± 50.0 mm (± 1.97 in.). Minimum bend radius is 15.00 mm (0.59 in.).
- 7 Tolerance for this dimension is: -0.38 mm (-0.015 in.).
- 8 Tolerance for this dimension is: +0.051 mm (+0.002 in.).
- 9 X-Y tolerance for this dimension is: TLY -0.051 mm (-0.002 in.). Length is untoleranced.

Motor Load Force Ratings

Motors are capable of operating with a sustained shaft load. The radial and axial load force location, and maximum values are provided.

Load Forces on the Shaft

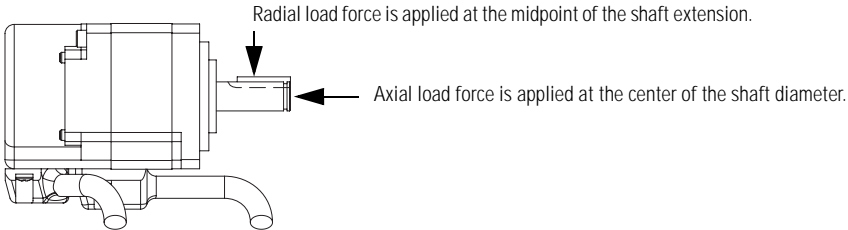

The following tables represent 20,000-hour L10 bearing fatigue life at various loads and speeds. The 20,000-hour life does not account for application-specific life reduction that can occur due to bearing grease contamination from external sources.

Loads are measured in pounds. Kilograms are a mathematical conversion.

Radial Load Force Ratings

Motor	1000 rpm		2000 rpm		3000 rpm		4500 rpm		5000 rpm	
	kg	(lb)	kg	(lb)	kg	(lb)	kg	(lb)	kg	(lb)
TLY-A110	11	(24)	9	(19)	7	(16)	-	-	6	(14)
TLY-A120	12	(26)	10	(21)	8	(18)	-	-	7	(15)
TLY-A130	13	(29)	10	(23)	9	(20)	-	-	8	(17)
TLY-A220	27	(60)	22	(48)	19	(42)	-	-	16	(35)
TLY-A230	31	(68)	24	(54)	21	(47)	-	-	18	(40)
TLY-A2530	48	(106)	38	(84)	34	(74)	-	-	28	(62)
TLY-A2540	50	(110)	39	(87)	34	(76)	-	-	29	(64)
TLY-A310	80	(177)	64	(140)	56	(123)	47	(103)	-	-

Axial Load Force Ratings (maximum radial load)

Motor	1000 rpm		2000 rpm		3000 rpm		4500 rpm		5000 rpm	
	kg	(lb)	kg	(lb)	kg	(lb)	kg	(lb)	kg	(lb)
TLY-A110	8	(18)	6	(14)	5	(10)	–	–	4	(9)
TLY-A120	9	(20)	7	(16)	5	(12)	–	–	5	(10)
TLY-A130	10	(22)	8	(17)	6	(13)	–	–	5	(11)
TLY-A220	15	(32)	11	(24)	9	(20)	–	–	7	(16)
TLY-A230	15	(34)	12	(26)	10	(21)	–	–	8	(17)
TLY-A2530	18	(39)	13	(29)	11	(24)	–	–	9	(19)
TLY-A2540	18	(39)	13	(29)	11	(25)	–	–	9	(20)
TLY-A310	24	(54)	18	(40)	15	(34)	12	(27)	–	–

Axial Load Force Ratings (zero radial load)

Motor	1000 rpm		2000 rpm		3000 rpm		4500 rpm		5000 rpm	
	kg	(lb)	kg	(lb)	kg	(lb)	kg	(lb)	kg	(lb)
TLY-A110	12	(26)	9	(20)	7	(16)	–	–	6	(13)
TLY-A120	12	(26)	9	(20)	7	(16)	–	–	6	(13)
TLY-A130	12	(26)	9	(20)	7	(16)	–	–	6	(13)
TLY-A220	19	(41)	14	(30)	11	(25)	–	–	9	(20)
TLY-A230	19	(41)	14	(30)	11	(25)	–	–	9	(20)
TLY-A2530	23	(50)	17	(37)	14	(31)	–	–	11	(25)
TLY-A2540	23	(50)	17	(37)	14	(31)	–	–	11	(25)
TLY-A310	29	(65)	22	(48)	19	(41)	15	(32)	–	–

Connector Data

These tables provide signal descriptions for servo motors with TLY catalog numbers.

Absolute Encoder		
Feedback Connections		
Pin	Signal	
1...5	Reserved	—
6	BAT+	Brown
7...12	Reserved	—
13	DATA+	Blue
14	DATA-	Blue/black
15...21	Reserved	—
22	EPWR 5V	Red
23	ECOM & BAT-	Black
24	SHIELD	Drain wire
25...28	Reserved	—

Connector Pinouts Feedback Connector

Tyco AMP 206152-1

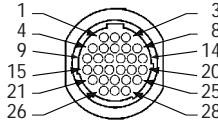

Incremental Encoder Feedback Connections

Pin	Signal	
1...8	Reserved	—
9	AM+	Green
10	AM-	Green/blk
11	BM+	Blue
12	BM-	Blue/blk
13	IM+	Yellow
14	IM-	Yellow/blk
15	S1+	Grey/blk
16	S1-	Grey
17	S2+	Brown/blk
18	S2-	Brown
19	S3+	White/blk
20	S3-	White
21	Reserved	—
22	EPWR 5V	Red
23	ECOM	Black
24	SHIELD	Drain wire
25...28	Reserved	—

Power and Brake Connections

Pin	Signal	
1	U phase	Red
2	V phase	White
3	W phase	Black
4	Reserved	—
5	Ground	Yellow/grn & drain wires
6	Reserved	—
7	MBRK+	Yellow
8	Reserved	—
9	MBRK-	Blue

Power and Brake Connector

Tyco AMP 206705-2

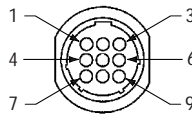

Power and Brake Connections

Pin	Signal	
1	U phase	Red
2	V phase	Black
3	W phase	White
4	Reserved	—
5	Ground	Yellow/grn & drain wires
6	Reserved	—
7	MBRK+	Yellow
8	Reserved	—
9	MBRK-	Blue

ATTENTION



Be sure that cables are installed and restrained to prevent uneven tension or flexing at the cable connectors. Excessive and uneven force at the cable connector may result in damage to the housing and contacts as the cable flexes. Failure to observe these safety procedures could result in damage to the motor and its components.

Connector Type	Feedback - 28 Position	Power - 9 Position	
Motor Connectors			
Connector housing	206152-1	206705-2	
Connector backshell	206070-8	206966-7	
Signal and power contact pins ⁽¹⁾		A110...A130	A220...A310
Reel	1658540-4 ⁽⁵⁾	66102-9 ⁽⁷⁾	66098-9 ⁽⁸⁾
Loose	1658540-5 ⁽⁵⁾	66103-4 ⁽⁷⁾	66099-4 ⁽⁸⁾
Ground contact pins ⁽²⁾	—		
Reel		164161-4	
Loose		164164-2	
Brake contact pins ⁽³⁾	—		
Reel		66106-8	
Loose		66107-4	
Compatible Connectors for Mating Cables			
Connector housing	205839-3	206708-1	
Connector backshell	206070-8	206966-7	
Contact sockets			
Reel	1658538-2 ⁽⁶⁾	66100-9 ⁽⁸⁾	
Loose	66505-9 ⁽⁶⁾	66101-4 ⁽⁸⁾	
Tools for Motor Connectors or Compatible Connectors			
Hand crimp tool	91503-1	58495-1	
Contact tool			
Extraction and insertion - feedback	91285-1		
Extraction - power and brake		305183	
Extraction - ground		725840-1	
Insertion - power, brake, and ground ⁽⁴⁾		91002-1	

Tyco AMP specifies wire sizing in AWG, mm² is a conversion from AWG in the footnotes.

- (1) For U, V, and W power phases in the power connector.
- (2) For motor frame ground in the power connector.
- (3) For motor brake in the power connector.
- (4) Use of the contact insertion tool is optional, as contacts are readily pushed by hand into the connector housing. After contacts are inserted into the connector housing, gently pull backward on each wire to be sure that contacts are fully seated and latched into position.
- (5) Wire range is 0.08...0.2 mm² (28...24 AWG).
- (6) Contacts and wire gauge used in Rockwell cables may vary by cable conductor. For reference only, the wire range of these contacts is 0.08...0.2 mm² (28...24 AWG).
- (7) Wire range is 0.2...0.6 mm² (24...20 AWG).
- (8) Wire range is 0.8...1.4 mm² (18...16 AWG).

Remove and Install a Shaft Key

Shaft keys are constructed of carbon steel. Keys for metric mount motors are toleranced for interference fit (slightly larger than the opening) to be sure of a secure and rigid fit with the mating connection. Keys for NEMA mount motors are toleranced for a slightly loose (slip) fit.

ATTENTION



Do not strike the shaft, key, couplings, or pulleys with tools during installation or removal.

Damage may occur to the motor bearings and the feedback device if sharp impact to the shaft is applied during installation of couplings and pulleys, or a shaft key. Damage to the feedback device also may result by applying leverage from the faceplate to remove devices mounted on the motor shaft.

Apply a constant pressure, with a wheel puller, to the user end of the shaft to remove from the motor shaft any friction fit or stuck device.

Failure to observe these safety procedures could result in damage to the motor and its components.

To remove a shaft key, perform one of the following actions.

- Lift the key by grasping it with a plier or similar tool.
- Lever the key with a flat-blade screwdriver inserted between the key and the slot.

To install a shaft key, follow these steps.

1. Verify that the replacement key matches the keyway in the shaft and the mating mechanical connection (for example, a coupling or pulley) before proceeding.
2. Align the front of the key with the front of the motor shaft. This prevents the radiused end-of-cut at the motor end of the keyway from interfering with correct seating of the key.
3. Support the underside of the shaft diameter with a fixture, and use a controlled press device to apply a constant force across the top surface to press the key into the shaft.

IMPORTANT

Check the motor shaft and surrounding surfaces. Remove any nicks, burrs, or surface damage. Significant grooving or damage will require service by Rockwell Automation to provide appropriate seal performance.

Key Alignment and Shaft Support

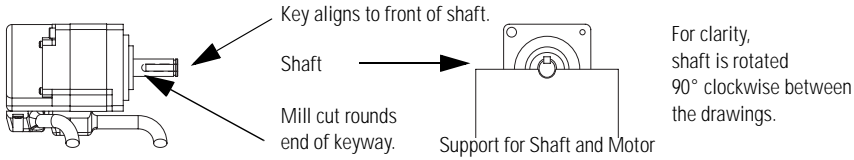

Specifications

The exterior surfaces of servo motors with TLY catalog numbers are made from the following materials. Always store a motor in a clean and dry location within these environmental conditions.

Surface	Material
Shaft	carbon steel
Shaft key	carbon steel
Housing of TLY-A1xx, TLY-A2xx, and TLY-A25xx.	aluminum and potting compound
Housing of TLY-A3xx	aluminum

Requirement	Description ⁽²⁾
Temperature, operating	0 ... 40 °C (32 ... 104 °F)
Temperature, storage	-10 ... 85 °C (14 ... 185 °F)
Relative humidity	20% ... 85% non-condensing
Atmosphere	non-corrosive
Motor with optional shaft seal ⁽¹⁾ IP65	dust tight, water jets
Motor without a shaft seal, and mounted in this direction.	
shaft down IP53	dust protected, spraying water
shaft horizontal IP51	dust protected, vertically falling water
shaft up IP50	dust protected, no special moisture protection
Cable connectors IP30	protected from objects greater than 2.5 mm (0.1 in.) in diameter, no special moisture protection

⁽¹⁾ An optional shaft seal kit is required to provide the IP65 rating (excludes lower rating for cable connectors). See Additional Resources on page 24 for Shaft Seal Installation Instructions.

⁽²⁾ IP rating descriptions are for reference only. Refer to the international standards for more complete rating descriptions.

Accessories

Accessories available from the factory include the following items.

Motor Cables

Factory manufactured feedback and power cables are available in standard cable lengths. Transition cables are available to allow connection of servo motors with TLY catalog numbers to existing N-Series power, feedback, and brake cables. Factory cables provide proper shield termination, which reduces the potential for EMI.

For a complete listing of available cables refer to your drive's installation manual, contact your nearest Rockwell Automation sales office, or access the information from the website references in Additional Resources on page 24.

Connector Kits

Each connector kit includes the appropriate connector housing, pins, and backshell.

Connector Kit	Catalog Number	Connector Kit	Catalog Number
Feedback Connector	2090-KFBM6-00AA	Power Connector	2090-KPBM6-16AA

Shaft Seal Kits

Catalog numbers and dimensions for shaft seals are shown below.

Motor	Catalog Number ⁽¹⁾	Inside Diameter		Outside Diameter		Width	
		mm	(in.)	mm	(in.)	mm	(in.)
TLY-A110, TLY-A120, TLY-A130	TL-SSN-1	8.9	(0.35)	16	(0.71)	3	(0.12)
TLY-A220, TLY-A230	TL-SSN-2	14.0	(0.55)	24	(0.95)	5	(0.20)
TLY-A2530, TLY-A2540, TLY-A310	TL-SSN-3	19.8	(0.78)	30	(1.18)	5	(0.20)

⁽¹⁾ Shaft seals require a lubricant to reduce wear. Lubricant is provided with kit.

Transition Cables

Transition cables interface between N-Series motor cables and the cables on servo motors with TLY catalog numbers with incremental encoders. The cables are 500 mm (20.0 in.) in length.

Feedback Cable Catalog Number	Power and Brake Cable Catalog Number	Power Only Cable Catalog Number
2090-CFBM6CN-04AA	2090-CPBM6CN-16AA	2090-CPWM6CN-16AA

Transition Plates

Transition mounting plates allow a TL-Series NEMA motor to physically replace an N-Series motor.

Catalog Number	Description	Compatible Motors	
		N-Series	TL-Series NEMA
TL-TRPLAT-17-23	TL Transition Plate, NEMA 17 to 23	N-23xx	TLY-A1xxx-xxxxN
TL-TRPLAT-23-34	TL Transition Plate, NEMA 23 to 34	N-34xx	TLY-A2xxx-xxxxN
TL-TRPLAT-34-42	TL Transition Plate, NEMA 34 to 42	N-42xx	TLY-A25xxx-xxxxN

Transition plates are not available for the N-56xx motors.

Additional Resources

For additional information about motors and compatible Rockwell Automation drives, refer to these publications.

For	Read this document	Publication Number
Connecting to a drive.	Kinetix 2000 User Manual Kinetix 6000 User Manual Ultra3000 Installation Manual Ultra3000 Integration Manual	2093-UM001 2094-UM001 2098-IN003 2098-IN005
Mounting TL-Series motor transition plates	TL-Series Installation Instructions	TL-IN002
Installing a shaft seal	Shaft Seal Installation Instructions	2090-IN012
Information about Kinetix products	Kinetix Motion Control Selection Guide	GMC-SG001
A glossary of industrial automation terms and abbreviations	Allen-Bradley Industrial Automation Glossary	AG-7.1

You can view or download publications at <http://literature.rockwellautomation.com>. To order paper copies of technical documentation, contact your local Rockwell Automation distributor or sales representative.

www.rockwellautomation.com

Power, Control and Information Solutions Headquarters

Americas: Rockwell Automation, 1201 South Second Street, Milwaukee, WI 53204-2496 USA, Tel: (1) 414.382.2000, Fax: (1) 414.382.4444
Europe/Middle East/Africa: Rockwell Automation, Vorstlaan/Boulevard du Souverain 36, 1170 Brussels, Belgium, Tel: (32) 2 663 0600, Fax: (32) 2 663 0640
Asia Pacific: Rockwell Automation, Level 14, Core F, Cyberport 3, 100 Cyberport Road, Hong Kong, Tel: (852) 2887 4788, Fax: (852) 2508 1846

Publication TL-IN003A-EN-P - June 2007

PN-13218

Copyright © 2007 Rockwell Automation, Inc. All rights reserved. Printed in the U.S.A.