

### Force

- **Peak: 46 - 92 N**
- **Continuous: 6 - 19N**

### Maximum Velocity

- **Up to 5.6 m/s**

### Feedback

- **Built-in position sensor**
- **1V pk-pk sin/cos**
- **12 micron repeatability**

### Range of motion

- **14~271 mm**

### Dimensions

- **W x H: 28 x 61mm**
- **Rod diameter: 11mm**

### Applications

- **Packaging**
- **Material Handling**
- **Automated Assembly**
- **Bio-medical**

### The OEM advantage

- **Reliable and cost-effective**
- **Flexible position control**
- **High speed and acceleration**
- **Clean, quiet operation**
- **No maintenance or adjustment**



The ServoTube Actuator is an optimal solution for industrial position control. Faster than a ballscrew with the clean reliability of a linear forcer, ServoTube is a cost-effective alternative to air cylinders in applications requiring greater flexibility and control.

The ServoTube Actuator incorporates an IP67 rated forcer and a sealed stainless steel thrust rod enclosing rare-earth magnets. Four models deliver a continuous force range of 9~27 N (2~6 lb) with peak forces up to 92 N (21 lb). 11 stroke lengths are available from 14~271 mm.

The patented magnetic design of ServoTube generates 12 micron (0.47 mil) repeatability and 350 micron (14 mil) accuracy from a non-contact, integral position sensor. No external encoder is required. Position output is industry standard 1V pk-pk sin/cos signals.

An internal dry bearing provides clean, quiet, maintenance-free performance. Life expectancy far exceeds typical ballscrew solutions.

The ServoTube Actuator is ideal for push/pull/lift material handling, packaging and automated assembly applications. ServoTube accepts a range of industry standard accessories for simple mechanical integration.

Flexible mid-stroke position control is simple with Accelnet - a matched, self-tuning indexer complete with plug-and-play cabling. Simply select your ServoTube model number and the system comes up tuned and ready to run. Clear diagnostics make system commissioning easy. Fill in the blanks to define position, velocity and acceleration.

Accelnet interfaces easily to PLCs and features CANopen network connectivity.

## ELECTRICAL SPECIFICATIONS

FORCER TYPE	1104	1108	1112	1116	units
Peak force @ 25°C ambient for 1 sec	46.0	53.0	68.9	91.9	N
Peak current @ 25°C ambient for 1 sec	12	12	12	12	Apk
<b>With 25 x 25 x2.5cm heatsink plate</b>					
Continuous stall force @ 25°C ambient <sup>(1)</sup>	9.27	15.78	21.44	26.75	N
Continuous stall current @ 25°C ambient	1.71	2.52	2.64	2.47	Arms
	2.41	3.56	3.74	3.50	Apk
<b>Without heatsink plate</b>					
Continuous stall force @ 25°C ambient <sup>(1)</sup>	6.02	10.83	15.18	19.28	N
Continuous stall current @ 25°C ambient	1.11	1.73	1.87	1.78	Arms
	1.58	2.45	2.64	2.52	Apk
Force constant (sine commutation)	5.42	6.26	8.12	10.83	N/Arms
	3.83	4.42	5.74	7.66	N/Apk
Back EMF constant (phase to phase)	4.42	5.10	6.63	8.84	Vpk/m/s
Fundamental forcer constant	1.75	2.49	3.05	3.52	N/√W
Eddy current loss	0.14	0.25	0.36	0.47	N/m/s
Resistance @ 25°C (phase to phase)	4.90	3.27	3.68	4.91	Ohm
Resistance @ 100°C (phase to phase)	6.32	4.29	4.74	6.31	Ohm
Inductance @ 1kHz (phase to phase)	1.15	0.99	0.87	1.15	mH
Electrical time constant	0.23	0.23	0.23	0.23	ms
Maximum working voltage	75	75	75	75	V d.c.
Pole pitch (one electrical cycle)	25.6	25.6	25.6	25.6	mm
Peak acceleration <sup>(2)</sup>	407	359	378	422	m/s <sup>2</sup>
Maximum speed <sup>(3)</sup>	5.3	5.6	5.4	4.7	m/s

### Notes: -

- <sup>(1)</sup> Reduce continuous stall force to 89% at 40°C ambient  
<sup>(2)</sup> Based on a moving thrust rod with 14mm stroke and no payload  
<sup>(3)</sup> Based on a moving thrust rod with triangular move over maximum stroke and no payload

## THERMAL SPECIFICATIONS

FORCER TYPE	1104	1108	1112	1116	units
Maximum phase temperature	100	100	100	100	°C
Thermal resistance Rth <sub>phase-housing</sub>	1.48	0.72	0.47	0.35	°C/Watt
<b>With 25 x 25 x2.5cm heatsink plate</b>					
Power dissipation @ 25°C ambient	27.6	40.1	49.7	58.0	Watt
Thermal resistance Rth <sub>housing-ambient</sub>	1.24	1.15	1.04	0.94	°C/Watt
<b>Without heatsink plate</b>					
Power dissipation @ 25°C ambient	11.8	18.9	24.8	30.0	Watt
Thermal resistance Rth <sub>housing-ambient</sub>	4.88	3.24	2.55	2.15	°C/Watt
Thermal time constant	142	176	202	223	s

## MECHANICAL SPECIFICATIONS

FORCER TYPE	1104	1108	1112	1116	units
Maximum stroke	245	245	271	271	mm
Forcer mass (excluding thrust rod and cable)	240	390	520	650	gram
Thrust rod mass/metre	0.68	0.68	0.68	0.68	kg/m
Integrated bearing type	2 x plastic polymer, self-lubricating, self-aligning				-

## OUTLINE DRAWINGS

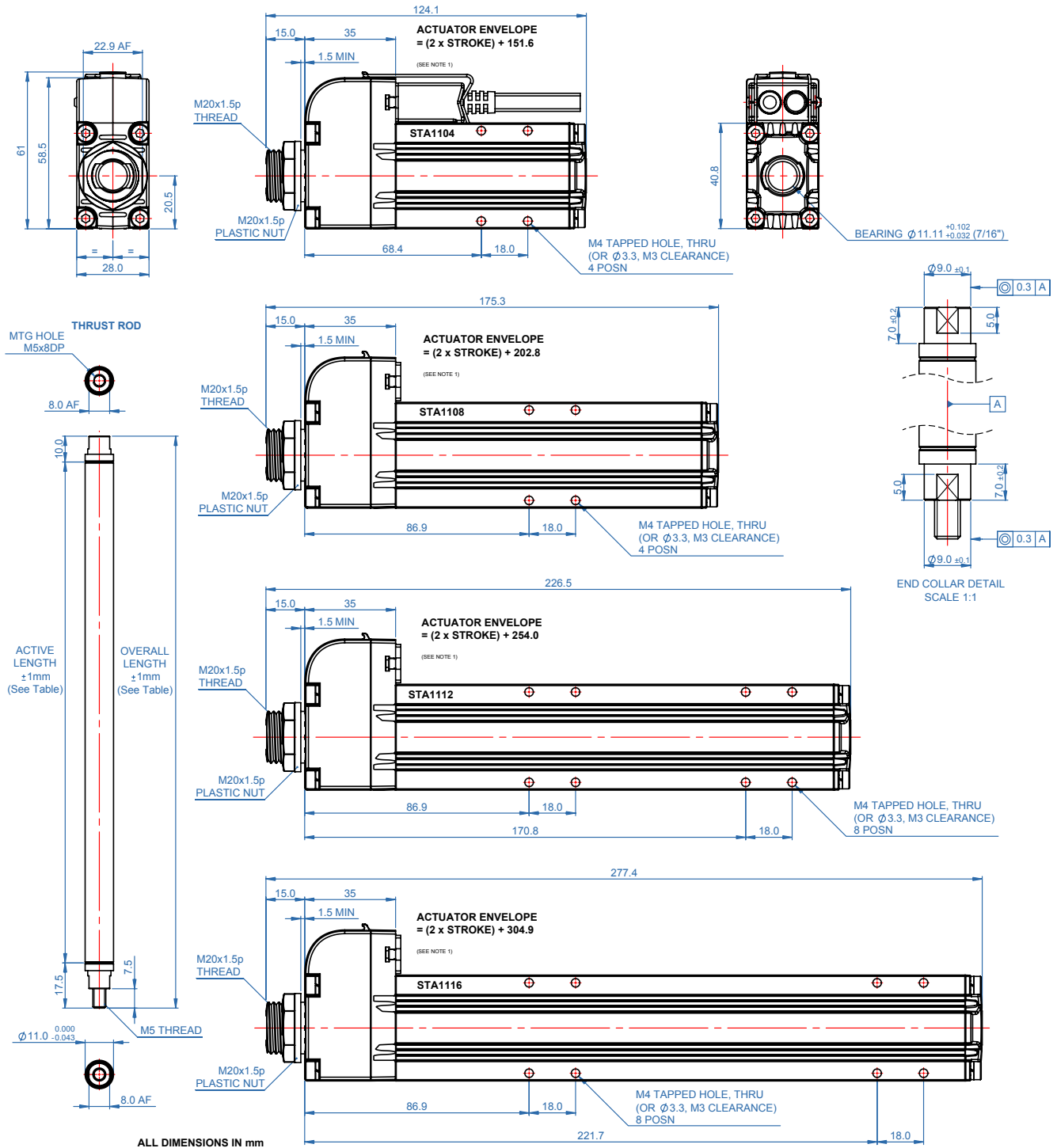

Stroke (mm)	1104		1108		1112		1116	
	OVERALL	ACTIVE	OVERALL	ACTIVE	OVERALL	ACTIVE	OVERALL	ACTIVE
14	166	139	217	190	268	241	319	292
39	191	164	242	215	293	266	344	317
65	217	190	268	241	319	292	370	343
91	243	216	294	267	345	318	396	369
116	268	241	319	292	370	343	421	394
142	294	267	345	318	396	369	447	420
168	320	293	371	344	422	395	473	446
194	346	319	397	370	448	421	499	472
219	371	344	422	395	473	446	524	497
245	397	370	448	421	499	472	550	523
271	-	-	-	-	525	498	576	549

**POSITION SENSOR**

The position sensor outputs analogue, differential sine and cosine signals for providing position feedback. Shown below are the relationships between forcer phase back EMF and position sensor outputs for one direction of motion (as shown by arrows).

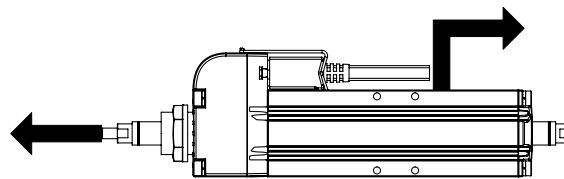
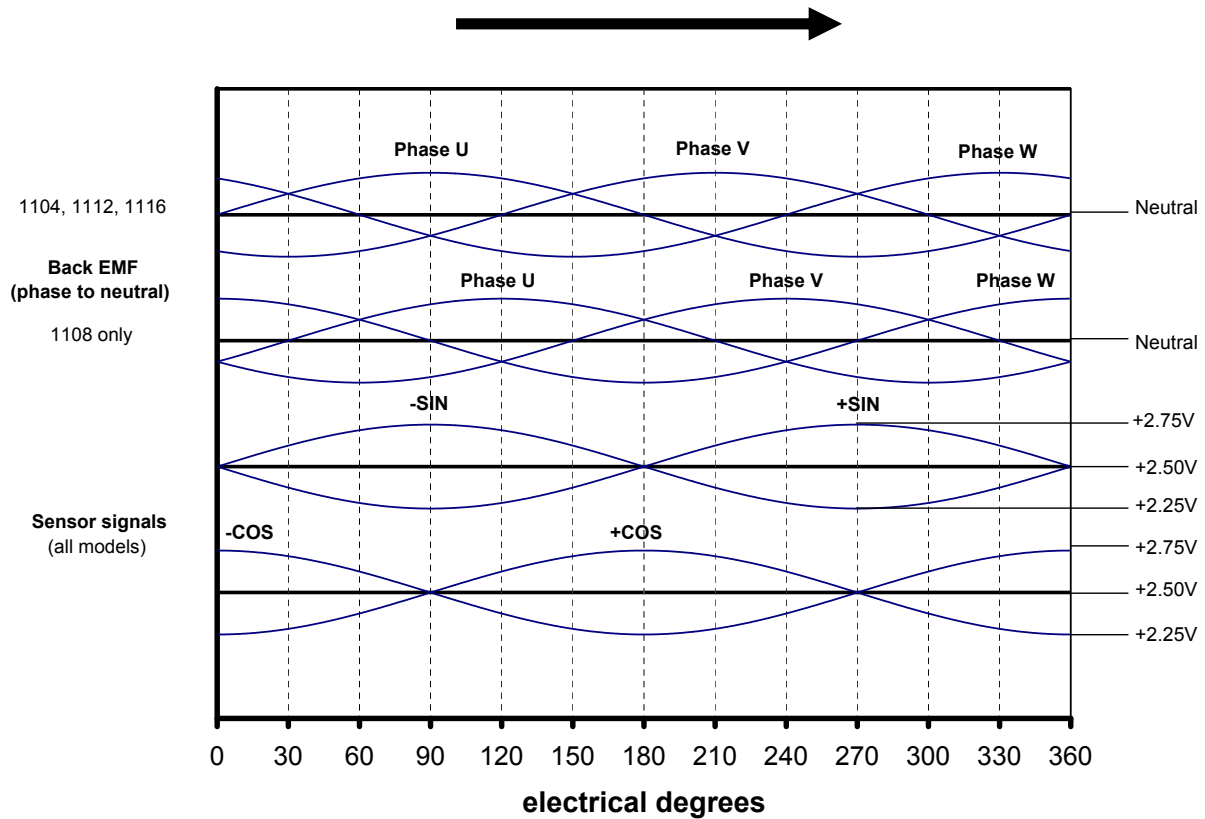

SPECIFICATION	VALUE	units
Output signal period	25.6	mm
Signal amplitude (between +/- signals)	1	Vpk-pk
Output current	$\pm 10$	mA
Supply voltage	$5 \pm 0.25$	Vd.c.
Supply current (output current=0)	$32 \pm 5$	mA
Resolution <sup>(1)</sup>	8	micron
Position repeatability <sup>(2)</sup>	$\pm 12$	micron
Absolute accuracy <sup>(3)</sup>	$\pm 350$	micron

**Notes: -**

<sup>(1)</sup> Dependent on amplifier

<sup>(2)</sup> Dependent on amplifier. Under constant operating conditions. Self-heating of the forcer will cause expansion in the thrust rod during the initial warm up period. In high duty applications (corresponding to an internal forcer temperature of 80°C) a 0.5 metre thrust rod will expand typically by 125 microns.

<sup>(3)</sup> Maximum error over 0.5 metre under constant operating conditions.

## FORCER OVER TEMPERATURE SENSOR



It is strongly recommended that the forcer over-temperature sensor is connected to the drive amplifier or servo controller **at all times** in order to reduce the risk of damage to the forcer due to excessive temperatures.

Protection is provided by a positive temperature coefficient (PTC) thermistor embedded in the forcer phases. As the forcer phase temperature approaches 100°C, the PTC thermistor exhibits a sharp increase in electrical resistance. This change in resistance can be detected by circuitry within the drive amplifier or servo controller and used to reduce or disable the output of the drive amplifier in order to protect the forcer.

SPECIFICATION	VALUE	units
Resistance at 25°C	235 to 705	Ohms
Resistance at 95°C	4700	Ohms
Resistance at 100°C	10000	Ohms
Maximum continuous voltage	32	Vd.c.

## FORCER ELECTRICAL CONNECTIONS

Connections on the forcer are available via a 15-way high density D-sub male connector. Connections are as follows: -

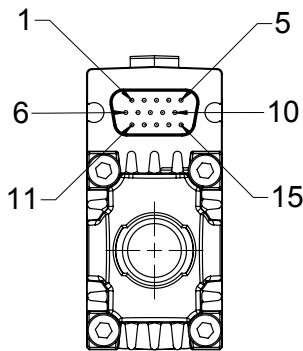

PIN NUMBER	FUNCTION
1	+SIN
2	-SIN
3	+COS
4	-COS
5	+5Vd.c.
6	0V
7	+TH (Thermistor)
8	-TH (Thermistor)
9	Factory use only
10	Factory use only
11	No connection
12	Earth (forcer body)
13	Forcer phase U
14	Forcer phase V
15	Forcer phase W
Connector body	SCREEN

## CABLE TYPE

The STA has a cable assembly that comprises power and sensor cables with a 15 way high density D-sub female connector for direct connection to the forcer. There are two cable types available with option S being supplied as standard. Both cable types are available in 3 metre or 5 metre lengths.

**Option S** cables are flexible but are not intended for continuous flex or energy chain applications.

OPTION S SPECIFICATION	POWER	SENSOR
Overall diameter (nominal)	5.3mm	6.5mm
Outer jacket material	PVC	PVC
Number of conductors	4	4 x twisted pair
Size of conductors	0.34mm <sup>2</sup> (22 AWG)	0.14mm <sup>2</sup> (26AWG)
Screened / Unscreened	Screened	Screened
Minimum bending radius - fixed routing	27mm	33mm
Operating temperature - fixed routing	-30°C to +70°C	-30°C to +70°C

**Option R** cables are suitable for continuous flex or energy chain applications.

OPTION R SPECIFICATION	POWER	SENSOR
Overall diameter (nominal)	4.7mm	5.8mm
Outer jacket material	PUR	PUR
Number of conductors	4	4 x twisted pair
Size of conductors	0.34mm <sup>2</sup> (22 AWG)	0.14mm <sup>2</sup> (26AWG)
Screened / Unscreened	Screened	Screened
Minimum bending radius - flexible routing	36mm	44mm
Operating temperature - flexible routing	-40°C to +90°C	-40°C to +90°C
Operating temperature - fixed routing	-50°C to +90°C	-50°C to +90°C

## CABLE TERMINATION

The STA cable is available with two termination options. **Option F** has the wire ends stripped and solder tinned ready for termination. **Option C** is terminated with connectors that plug directly into a Copley Accelnet Micro Panel amplifier (ACJ-S). The connections for both options are shown below: -

SENSOR FUNCTION	F-FLYING LEADS	C-ACCELNET MICRO PANEL
+SIN	Blue	8
-SIN	Red	1
+COS	White	9
-COS	Brown	2
+5Vd.c.	Yellow	4
0V	Green	11
+TH (Thermistor)	Pink	7
-TH (Thermistor)	Grey	6
SCREEN	SCREEN	14
Connector type	-	Samtec IPD1-07-D
Amplifier connection	-	J4
POWER FUNCTION		
Forcer phase U	Yellow	4
Forcer phase V	White	3
Forcer phase W	Brown	2
Earth (forcer body)	Green	1
SCREEN	SCREEN	1
Connector type	-	Molex 39-01-4051
Amplifier connection	-	J2

## ENVIRONMENT

The STA is intended for use in an environment within the following conditions: -

SPECIFICATION	VALUE
Operating temperature	0°C to +40°C
Storage temperature	-25°C to +70°C
Ingress protection	IP67
Altitude (above mean sea level)	1000m
Overvoltage category	II
Pollution degree	2
EMC	light industrial

In addition, the STA is available with two environmental coating options. **Option S** has the forcer body coated with a 25 micron layer of black anodise that is suitable for general use. **Option H** has the forcer body coated with a 90 micron layer of hard natural anodise that is suitable for harsher environments.

**ORDER CODES**

**Actuator**

**STA11** □ □ - □ □ □ - □ - □ □ □ - □

**Forcer**  
04, 08, 12, 16

**Stroke**  
014, 039, 065, 091, 116,  
142, 168, 194, 219, 245, 271

**Stroke in mm**  
Note: 271 not available on 04  
and 08 forcers

**Environment**  
S - Standard  
H - Harsh

**Cable Termination**  
C - Copley Accelnet Micro Panel (ACJ-S)  
F - Flying leads

**Cable Length**  
03 - 3 metre  
05 - 5 metre

**Cable Type**  
S - Non-Robotic  
R - Robotic

**Spare forcer only (with cable)**

**STS11** □ □ - □ - □ □ □ - □

**Forcer**  
04, 08, 12, 16

**Environment**  
S - Standard  
H - Harsh

**Cable Termination**  
C - Copley Accelnet Micro Panel (ACJ-S)  
F - Flying leads

**Cable Length**  
03 - 3 metre  
05 - 5 metre

**Cable Type**  
S - Non-Robotic  
R - Robotic

**Spare forcer only (without cable)**

**STS11** □ □ - □ - N

**Forcer**  
04, 08, 12, 16

**Environment**  
S - Standard  
H - Harsh

**Spare thrust rod only**

**TRS11** □ □ - □ □ □

**Forcer**  
04, 08, 12, 16

**Stroke**  
014, 039, 065, 091, 116,  
142, 168, 194, 219, 245, 271

**Stroke in mm**  
Note: 271 not available on 04  
and 08 forcers